



CB-214E

CB-224E

Asphalt Compactors

CB-225E

Combi Asphalt Compactor



	CB-214E	CB-224E	CB-224E Heavy Weight	CB-225E Combi
Operating weight (with ROPS)	2450 kg	2630 kg	3125 kg	2300 kg
Compaction width	1000 mm	1200 mm	1200 mm	1200 mm
Gross power	24.4 kW/32.7 hp	24.4 kW/32.7 hp	24.4 kW/32.7 hp	24.4 kW/32.7 hp

Production-Sized Results in Small Packages

Maneuverability, transportability and versatility are combined in easy-to-operate machines that will help you meet and exceed your tons-per-day production needs.



Versatility. The CB-214E, CB-224E and CB-225E are versatile machines that can be used as the only compactor on small sized jobs or on larger jobs as a support roller for high-production compactors. As a support roller, they work well for turning lanes, cross-overs, shoulders and other similar sized jobs.

Wide drums. With its 1000 mm wide drums, the CB-214E is well suited for rental customers and contractors or agencies that maintain streets, roads, alleys or are adding paths to parks and recreation areas. In these applications, the tight turning radius and easy maneuverability make it a perfect match.

Production capabilities. The CB-224E provides greater production capabilities with its 1200 mm wide drums. Its high amplitude and drum width give it the capacity to achieve a tons-per-day production rate that make it an excellent match for shoulders, small parking lots, lane additions or other similar sized jobs.

Versatility driven. Meanwhile, the CB-225E is versatility driven. Its steel front drum and rubber tired rear wheels allow it to function as both a vibratory and a pneumatic compactor. The CB-225E produces a tight mat with a smooth finish.

Comfortable and convenient operating environment. All three machines provide a comfortable and convenient operating environment that contribute to the versatility of the machines. The roomy operator's station provides excellent visibility to drum edge or tire contact points. Their low-profile design provides great visibility to the front or rear.

Quiet machine. In addition, the machines are quiet for the operator and spectators, especially beneficial on commercial jobs when compaction must coincide with day-to-day business operations.

Extensive dealer network. Caterpillar compactors are supported by an extensive dealer network and parts distribution system as well as by Caterpillar dealer representatives that are highly trained and motivated. Caterpillar offers a comprehensive line of asphalt pavers, cold planers, compactors, reclaimers and stabilizers.

Caterpillar® 3013C Engine

Reliable and durable diesel engines for years of low maintenance operation.



Balance and speed. Precise balance and optimum running speed for quiet and efficient operation.

Liquid-cooled engine. The liquid-cooled engine operates at low temperature helping reduce component wear.

Injection timing. Variable injection timing provides highly efficient combustion eliminating visible smoke.

Oil service interval. Standard 500 hour oil service interval reduces operating costs.

Stage II compliant. Engine meets EU Stage II off highway emissions standards.

Vibratory System

Precise system delivers optimum compactive force.

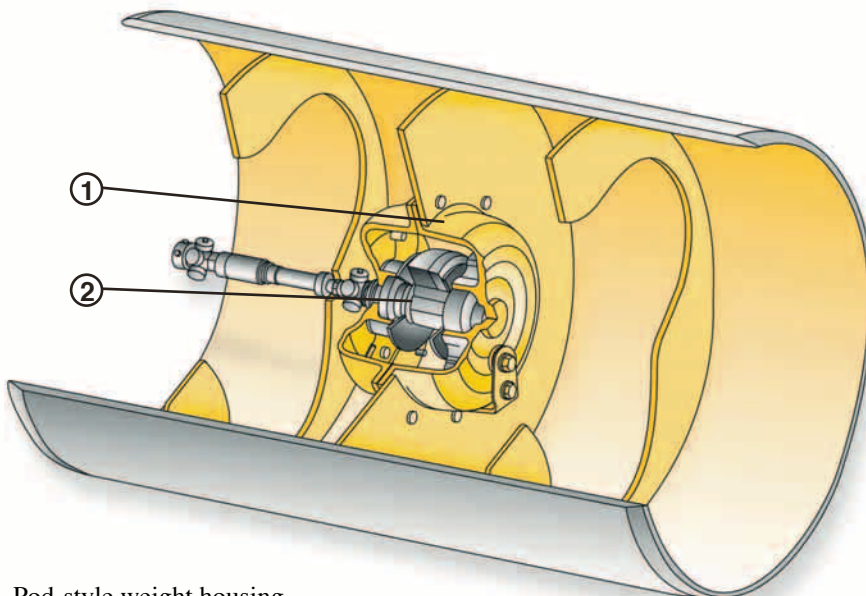

1 Pod-style weight housing

2 Fixed eccentric weight

Pod-style weight housings. They are assembled and sealed at the factory to ensure cleanliness, extended bearing life and easy field exchange/service.

Bearing lubrication. Change interval for bearing lubrication is every three years or 3000 hours.

Frequency and amplitude.

Balance between frequency and amplitude provides a good mat finish for commercial work.

Vibratory delay. Vibratory delay option allows front drum to vibrate before the rear drum.

Operator Comfort

Operating ease and comfort promote all-day productivity.



Single propel lever control.

It provides simplified operation, making the machines a perfect fit for operators.

Instrument panel. Easy-to-understand instrument panel integrates warning lights for main functions, fuel gauge, water spray and switches, allowing the operator to quickly verify the status of machine systems.

Sound levels. Low sound levels make the machines comfortable for both operators and spectators.

Operator's Station

The machines for EC territories are equipped with a suspended seat with switch that prevents movement of the machine if the operator is not seated.



Seat. Durable suspension or non-suspension seat arrangements offer day long comfort.

Ignition key switch. The ignition key switch automatically enables engine pre-heat system.

Operator's station. The operator's station is isolated with four rubber mounts that help eliminate vibration before it reaches the operator, controls and instrumentation.

Lockable cover. The lockable cover protects instrumentation and gauges.

This machine is shown with an optional sliding seat. See optional equipment (pg. 11) for seat and operator station configurations.

Excellent Forward and Rearward Visibility

Low-profile design provides convenient control of machines.



Forward visibility. Excellent forward visibility allows the operator to see objects 0.58 m high and 1 m in front of the machine.

Rearward visibility. Rearward visibility is even better. Operator can see objects that are 0.35 m behind the machine and flush to the surface.

Engine enclosure. The low-profile engine enclosure provides unobstructed sight lines to ground personnel working near machine.

Water Spray System

Corrosion-proof system and extended-life components provide reliable operation.



Spray capabilities. Constant or intermittent spray capabilities provide extended operation between refills.

Water filtration. Triple water filtration reduces machine downtime caused by system clogs.

Water pump. Extended-life water pump provides optimum spray and flow.

Water pump and filters. They are conveniently located for easy access.

Water tank drain. Large water tank drain allows system to be drained in less than five minutes.

Spray bar shields. Optional front and rear spray bar shields prevent wind displacement of water.

Optional water tank. Optional 70 liter water tank increases production between refills (CB-214E and CB-224E only).

Drum Design Keeps Production High

Machined drum surfaces help ensure a smooth mat.



Drum edges. Specially designed drum edges help eliminate marks on deep lifts or when turning.

Rolled steel plate. Drums are constructed of rolled steel plate and are finished to reduce surface irregularities.

Rubber mounts. Replaceable rubber mounts isolate vibration and enhance vibratory capabilities.

Self-adjusting scrapers. Each drum is fitted with two retractable, spring-loaded, self-adjusting scrapers, positioned at the front and rear of each drum.

Steel plates. Ends of each drum are fitted with steel plates that help prevent rocks, soil, asphalt or other material from entering the ends of the drums.

Tires Enhance Versatility – CB-225E

Tires manipulate the mat under and between its wheels.



Front drum and rear rubber tires.

Steel front drum and rubber tires at the rear allow a single machine to function as both a double drum and pneumatic compactor.

Rubber tires. Four rubber tires generate a high ground contact pressure that penetrates deep into the lift.

Flexible tires. Because the tires are flexible, horizontal pressures develop, assisting with compaction.

Adjustable scraper. Each tire is fitted with a replaceable, adjustable scraper. The scrapers can be positioned above the tires when they are not needed.

Serviceability

Time-saving features reduce maintenance requirements and increase production.



Engine enclosure. Fiberglass engine enclosure pivots upward and locks open with a prop rod.

Service points. External engine components, hydraulics and routine service points are clustered in easy-to-access locations.

Daily Visual Maintenance. Daily Visual Maintenance system simplifies verification of fluid levels and filter conditions.

Oils. Extended-life oils increase maintenance intervals for the vibratory system, hydraulic system and engine oil.

Drains. Remote-mounted drains for hydraulic and engine oils provide simplified collection of fluids.

Hydraulic test ports. Quick-connect hydraulic test ports simplify system diagnosis.

Wiring. Electrical wiring is color-coded and numbered for simple troubleshooting.

All-weather connectors. Nylon-braided wrap and all-weather connectors ensure electrical system integrity.

Engine

Caterpillar 3013C naturally aspirated, water-cooled, 4-stroke, 3-cylinder diesel engine. Meets 97/68/EC Stage II emission standards.

Ratings at 2800 rpm	kW	hp
Gross power	24.4	32.7

The following ratings apply at 2800 rpm when tested under the conditions for the specified standard:

Net Power	kW	hp
ISO 9249	23	30.8
EEC80/1269	23	30.8

Net power advertised is the power available at the flywheel when the engine is equipped with fan, air cleaner, muffler, and alternator.

Dimensions

Bore	84 mm
Stroke	90 mm
Displacement	1496 cm ³

Dual-element, dry-type air cleaner with visual restriction indicator.

Brakes

Brake systems meet ISO 3450 and EN500-4.

Service

- Closed-loop hydrostatic drive system provides dynamic braking during machine operation.

Secondary and Parking

- A spring-applied, pressure-released brake inside each propel motor immobilizes the roller. Activation is by a switch on the operator's console or when the engine is shut off.

Transmission

CB-214E and CB-224E – Variable-displacement piston pump supplies pressure flow to fixed-displacement hydraulic motors that drive the front and rear drums.

CB-225E – Variable-displacement piston pump supplies pressure flow to a fixed-displacement hydraulic motor that drives the front drum, and the pump supplies pressure flow to two fixed-displacement motors that drive the rear wheels.

A propel lever located at the operator's station provides smooth hydrostatic control of the infinitely variable speeds in both forward and reverse.

Speed

CB-214E/224E/225E	0-10 km/h
CB-224E Heavy Weight	0-7.5 km/h

Final Drives

CB-214E and CB-224E – High-torque, low-speed hydraulic motors directly drive each drum.

CB-225E – High-torque, low-speed hydraulic motor directly drives the front drum, and two high-torque, low-speed hydraulic motors directly drive the rear wheels.

Instrumentation

The control console includes: steering wheel; water spray system switch; vibratory drum selector switch; horn; hazard flasher control; engine start switch with preheat; parking brake. The instrument panel cluster integrates the fuel level indicator, service hour meter and also light indicators for: roading lights, parking brake, hydraulic oil temperature, engine coolant temperature, alternator, engine oil pressure, vibration on, engine preheat, turn signals. The vibratory system is actuated with a switch on the top of the propel lever. When the vibratory system is activated, a vibration indicator light illuminates. The engine throttle control is located on the right side of the control console pedestal. If equipped with optional light packages, switches are located on the control console.

The machine is protected from vandalism with several covers. The control console, hood and compartment for the Operation and Maintenance Manual are equipped with lockable covers.

Steering

An engine-driven gear-type pump supplies hydraulic fluid for the steering circuit.

Minimum turning radius

	CB-214E
Inside drum edge	2510 mm
Outside drum edge	3510 mm
CB-224E/CB-225E	
Inside drum edge	2410 mm
Outside drum edge	3610 mm
Steering angle	32°

Hydraulic system: One 70 mm bore, double-acting cylinder powered by a gear-type pump. Output at 2800 rpm is 23 liter/min with relief valve at 117 bar.

Electrical System

The 12-volt electrical system includes one maintenance-free Cat battery and color-coded and numbered wiring wrapped in nylon braid. The system includes a 55-amp alternator. The starting system provides 650 cold cranking amps.

Frame

Frame is fabricated from heavy gauge steel plate and joined at the center articulation pivot. Two self-aligning bearings on the pivot housing provide a ± 32 degrees steering angle, and a horizontal pin provides a ± 10 degrees oscillation angle. The articulation pivot is structurally reinforced for extended service life. For transport purposes, the articulation pivot can be secured at the zero steering angle.

Water Spray System

Spray bars are constructed of stainless steel for corrosion resistance. The water tank is reinforced polyethylene. An electric water pump provides either continuous or intermittent spray. Intermittent spray setting increases spray time by 50 percent over continuous setting. Triple filtration includes a filter on the tank fill spout, an in-line filter at the water pump and filters on each spray nozzle. Spray nozzles are easily removed without tools for cleaning.

Capacity 150 liters

Sound Levels

The operator sound level measured according to the procedures specified in ISO 6394:1998 is 80 dB(A). The labeled sound power level is 109 dB(A) measured according to the test procedures and conditions specified in 2000/14/EC.

Service Refill Capacities

	Liters
Fuel Tank	46.5
Crankcase	6
Hydraulic fluid tank	26
Hydraulic circuit	30
Drum spray system	150
Tire wetting system	70

Weights

Operating weights include lubricants, 80 kg operator, full fuel tank, full hydraulic system and half-full water tanks (all weights are approximate).

	CB-214E	CB-224E	CB-224E Heavy Weight	CB-225E
	kg	kg	kg	kg
Operating without ROPS	2390	2570	–	2240
at front drum	1150	1250	–	1280
at rear drum	1240	1320	–	–
at rear wheels	–	–	–	960
weight per rear wheel	–	–	–	240
Operating with ROPS	2450	2630	3125	2300
at front drum	1150	1250	1560	1280
at rear drum	1300	1380	1565	–
at rear wheels	–	–	–	1020
weight per rear wheel	–	–	–	255

Wheels and Tires

CB-225E – 9.5/65-15 6-ply tires are standard. Each tire is equipped with a replaceable scraper. The scrapers help clean asphalt or soil off the tires. The scrapers can be positioned above the tires when they are not needed. Wheels are on a fixed axle.

Tire Wetting System

Tire Wetting System allows a solvent to be sprayed on the tire surfaces, helping prevent asphalt from adhering to the tires. One spray nozzle is positioned above each tire. The system is controlled with an on/off switch on the control console.

Capacity 70 liters

Dimensions

All dimensions are approximate.

	CB-214E	CB-224E	CB-224E Heavy Weight	CB-225E
	mm	mm	mm	mm
A Length	2430	2430	2430	2430
B Wheelbase	1730	1730	1730	1730
C Drum diameter	700	700	720	700
Drum shell thickness	13.5	13.5	23.5	13.5
D Tire diameter				9.5/65-15K 6-ply
E Height at steering wheel	1807	1807	1817	1807
F Height at ROPS	2589	2589	2599	2586
G Ground clearance	254	254	264	254
H Curb clearance	519	519	529	519
I Compaction width	1000	1200	1200	1200
J Machine width	1100	1300	1300	1300

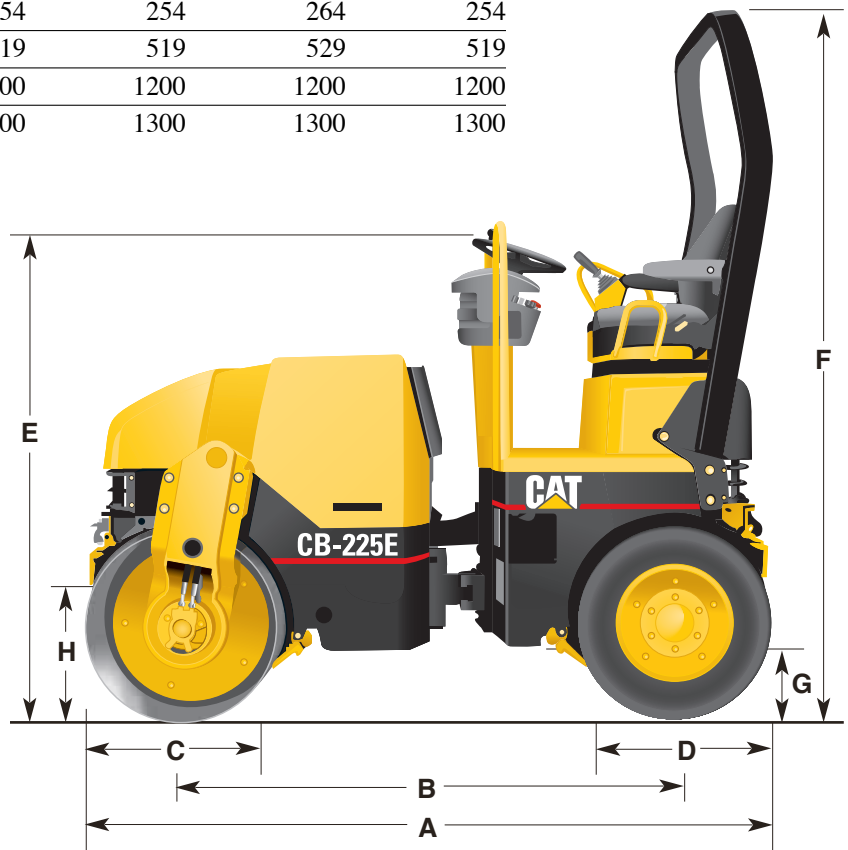

Compaction Characteristics

	CB-214E	CB-224E	CB-224E Heavy Weight	CB-225E
Vibration selections	Front or both	Front or both	Front or both	Front
Eccentric weight drive	Hydraulic	Hydraulic	Hydraulic	Hydraulic
Frequency	63 Hz	63 Hz	63 Hz	63 Hz
Nominal amplitude	0.5 mm	0.5 mm	0.3 mm	0.5 mm
Centrifugal force per drum	27.6 kN	31.4 kN	31.4 kN	31.4 kN
Load per cm of drum contact – Static	12.3 kg/cm	11.0 kg/cm	13.0 kg/cm	10.7 kg/cm

Optional Equipment

Standard and optional equipment may vary. Consult your Caterpillar dealer for specifics.

Roll Over Protective Structure (ROPS)

is a two-post structure that bolts directly onto flanges welded to the machine frame. The ROPS meets ISO 3471 and EN 500-4.

Foldable ROPS includes pivots that allows ROPS to fold, lowering shipping height. ROPS meets ISO 3471 and EN 500-4. The foldable ROPS is not compatible with the CB-224E Heavy Weight.

Sun Canopy is a thermo-formed plastic structure that blocks the operator's station from the sun. Structure is bolted to the ROPS.

Work Light Package consists of two front headlights and one independent rear work light.

Roading and Working Light Package consists of two front headlights, two rear taillights, two front-position lights, turn signals, hazard lights and one independent rear work light.

Rotating Beacon includes an amber beacon and mount that can be attached to machines with or without ROPS.

Spark Arrestor Muffler helps eliminate burning carbon particles that can exit the muffler.

Back-up Alarm emits a high-pitched sound when the machine is in reverse.

Suspension Seat provides armrests, fore/aft and height adjustments.

Suspension Seat with Seat Switch provides armrests, fore and aft adjustment and a seat switch. The seat switch prevents movement of the machine when the operator is not seated. This arrangement is standard in the European Union.

Sliding Operator Station allows three different operating positions, left, center and right.

Coco Mats retain water as it is distributed by the water spray system. The mats allow water to seep out of them, providing continuous water distribution to drum surfaces.

Heat Retention Device helps trap heat and warms the tires on the CB-225E. The heat retention devices help eliminate asphalt from adhering to the tires.

Spray Bar Shields prevent uneven water distribution across the width of the drum due to wind.

Light Protector Grids prevent damage to the light assemblies.

Water Tank (additional) allows an extra 70 liters of water storage for a total capacity of 220 on the CB-2214E and CB-224E.

Traction Control transfers torque between the front and rear drum (CB-214E, CB-224E) for increased power on slopes.

Heavy Weight Option includes thicker drums and a specific ROPS that provide an additional 450 kg for increased versatility.

Exhaust Deflector modifies air flow under the front frame decreasing airborne particles.

Rear Drum Vibratory Control allows the operator to control the rear drum separately and includes the delay "ON" vibration system.

Delay "ON" Vibratory System controls the start of the rear drum to assist power management on slopes. Included in rear drum vibratory control.

Value Analysis

Versatile Operation

- High-frequency vibratory system
- CB-225E rubber tires make it effective on both asphalt and soil.

Productivity

- Responsive diesel power.
- High travel speeds.
- Nearly equal front-rear weight distribution.

Easy Control

- Single lever control of forward/reverse speeds.
- Low-effort steering.
- Excellent visibility.

Simplified Maintenance

- Simple, durable design.
- Rugged construction for extended service life.
- Easy access to all major components.

Total Customer Support System

Parts Availability – most parts on the dealers shelf when you need them. Computer controlled emergency search system backup.

Parts Stock Lists – dealer helps you plan on-site parts stock to minimize your parts investment while maximizing machine availability.

Service Capability – dealer's shop or fast field service by trained technicians using latest tools and technology.

Machine Management Services – effective preventive maintenance programs, cost-effective repair options, customer meetings, operator and mechanic training.

Literature Support – easy to use parts books, operation and maintenance manuals, and service manuals help you get maximum value equipment.

Flexible Financing – your dealer can arrange attractive financing on the entire line of Caterpillar equipment. Terms are structured to meet cash flow requirements. See how easy it is to own, lease or rent Caterpillar equipment.

CB-214E/CB-224E Asphalt Compactors

CB-225E Combi Asphalt Compactor

HEHG1032 (01/2004) ro

Materials and specifications are subject to change without notice.
Featured machines in photos may include additional equipment.
See your Caterpillar dealer for available options.

© 2004 Caterpillar

CATERPILLAR[®]